

OCULAR BOBBING COMPENSATION SYSTEM

Yucong Gu
University of Kansas
Lawrence, KS, USA

Yuchen Yan
University of Kansas
Lawrence, KS, USA

You Chen
University of Kansas
Lawrence, KS, USA

Tai Kim
University of Kansas
Lawrence, KS, USA

Faculty Advisor
Dr. Ken Fischer
University of Kansas
Lawrence, KS, USA

INTRODUCTION

The term “ocular bobbing” defines a distinctive class of abnormal, spontaneous, vertical eye movements which occur in a variety of clinical pathological settings [1]. For those ocular bobbing patients, their primary connection to the outside world depends on their vision. Besides ocular bobbing, they often have other central nervous system issues, like loss of hearing and inability to speak. Because of ocular bobbing, they are only able to read large print. Because of the involuntary eye movement, they typically communicate by a letter board or a touch screen computer. With ocular bobbing, the patients not only have limited muscular control of the eyes [2], but may also have intermittent blurred and/or double vision [3]. The inability to read small print creates many difficulties in their lives, such as being unable to read books or use a computer normally. Our goal is to help these patients to achieve a more normal vision, so that they can read books, watch TV, use a computer, and enjoy outdoor activities. At this moment, there is no device on the commercial market designed to improve the vision of patients with ocular bobbing.

PRODUCT DESIGN

We are taking a two-pronged approach: 1) attempting to develop a static optical compensator, and 2) developing a computer vision compensation system.

The static optical compensator is designed with a specific curvature aspheric lens to refract the view in front of the subject into subject’ pupil (Figure 1) regardless of their eye movement (angle of inclination). A second lens near the eye will refocus the image. The basic optical theory for this approach is refraction. When light transfers from one medium to another medium [4] [5], its direction will change due to the difference in the refraction index. The basic design includes a pair of special lenses in front of each of the patients’ eyes. These lenses will refract the light from the frontal view to his pupils, no matter what angle to which his eyes have rotated. In the final arrangement, this system will be essentially like a pair of specialized glasses, with two lenses per eye. Because it is not yet certain that both redirection and focus can be simultaneously achieved, an alternate solution is also being pursued.

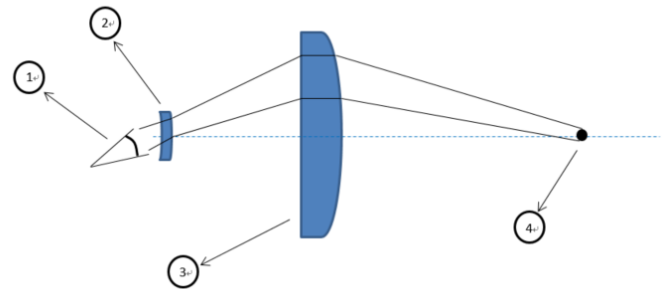

Figure 1: The schematic of the static optical compensator. The light travels from object ④ to eye ①; the path of light is changed by an aspheric lens ③, and refocused by a near-eye high-magnification lens ②

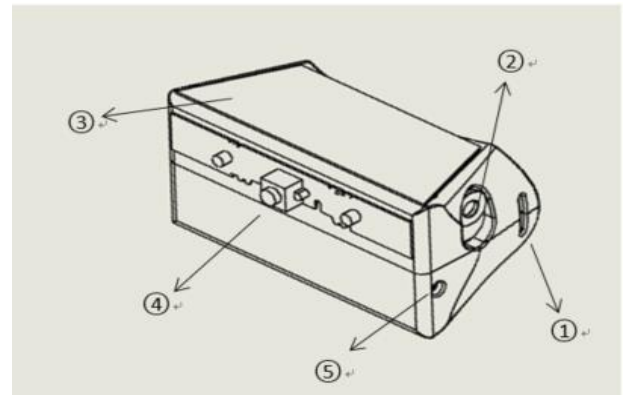

Figure 2: The Computer Vision Compensation System. ① is an attachment for the head strap, ② is the power switch, ③ is the outside case of the system, ④ is the front camera, and ⑤ is the power and communication input/output port.

The computer vision compensation system (Figure 2) utilizes a wearable display that stabilizes the front view for the subject with ocular bobbing. This system contains an eye tracking subsystem [6] and a dynamic display subsystem that moves with the eyes (Figure 3). A front camera (Logitech C920, Newark, California) captures the forward view, and sends real-time video to two small LCD displays (Fat Shark FPV, Stockholm, Sweden) in front of the user's eyes. The eye tracking system has a separate camera (Pixy, Austin, Texas) and two infrared LEDs; it tracks the user's eye movement. An Arduino UNO programmable micro controller drives a stepper motor to move the LCD displays and keep them directly in front of the eyes. The controller and battery pack will be in a remote case to reduce weight in the headset.

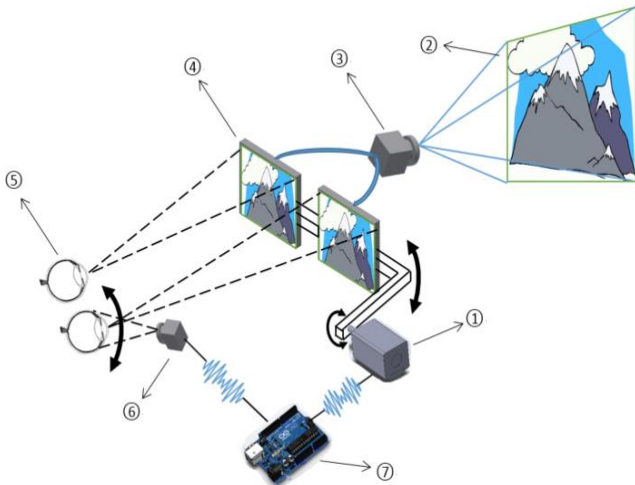

Figure 3: The schematic of the computer vision system. A front camera ③ captures the forward view ②, and sends the view to two small displays ④ in front of user's eyes ⑤. Based on the signals from the eye tracking system ⑥, the controller ⑦ drives a stepper motor ① to move the displays and keep them directly in front of the eyes.

The static lens approach is by far the superior approach if it can achieve the desired function. In terms of reliability and maintenance, there are no moving parts, batteries or electronics that could fail. In terms of aesthetics, the static lens approach provides a solution quite similar to standard eye glasses, and the subject's full face and even eyes are visible to those around him/her. However, even with optical system design software, it is not yet clear if the static lens system will be able to achieve both line of sight redirection and image clarity (focus). The computer vision system would cover the subject's eyes and likely make them self-conscious, at least as they begin to use it in public. Technically, there are challenges with this approach as well, though fundamentally the systems should work together to achieve the desired outcome.

BUDGET & MARKET ANALYSIS

The cost of the static optical compensator is currently projected to be under \$1000 for all four lenses and a custom frame system to hold them. The cost of the prototype computer vision compensation system is projected to be approximately \$2,000. The potential market size for this device does not appear to be large. No numbers on the condition are compiled by the Centers for Disease Control. There are only 1-2 clinical case reports of ocular bobbing in the literature each year. Thus, we estimate that there may be less than 50 new ocular bobbing patients each year in the USA. Given the very limited market, we plan to place the design(s) in the public domain, for use by individuals and non-profit groups to build, as desired, for those who need and want it. While the project does not appear to have commercialization potential, it will have a *tremendous impact* on the lives of individuals that receive an ocular bobbing compensation system, who once again have a stable field of vision.

ACKNOWLEDGEMENTS

We acknowledge grant funding from the National Science Foundation (CBET 1160130) through the University of Kansas Biomechanical Rehabilitation Engineering Advancement for Kansas (BREAK) program.

REFERENCES

- [1] Mehler, M et al., *Journal of Neurology, Neurosurgery, and Psychiatry*, 51, 725-727, 1988
- [2] RICHARD, R et al., *Journal of Neurology, Neurosurgery, and Psychiatry*, 44, 441-443, 1981
- [3] Robert B, J. *Neurol. Neurosurg. Psychiatr*, 28, 375-377, 1965
- [4] Hech E et al., *Optics 4th edition*, 2001
- [5] Max B et al., *Principles of Optics*, 38-39, 2003
- [6] Pelz, J et al., *ETRA '04 Proceedings of the 2004 symposium on Eye tracking research & applications*, 5, 109-113, 2004